

DESIGNED FOR ACCURACY, BUILT FOR TRUST

# TS1000T - PRELIMINARY DATASHEET

Single axis analog accelerometer

The new TS1000T is the best in class high temperature MEMS Accelerometer specifically design for Inertial directional drilling application. It offers the highest performance stability with shock resistance, as well as the lowest non-linearity and noise in the marketplace for MEMS. The proven MEMS technology by Colibrys is pushing forward the vibration and shock endurance in temperature.

Each products are systematically fully tested in production over temperature range. The internal signal analog conditioning offers a Built in Self-Test and overload functions for your confidence at all time.



Functional Block Diagram

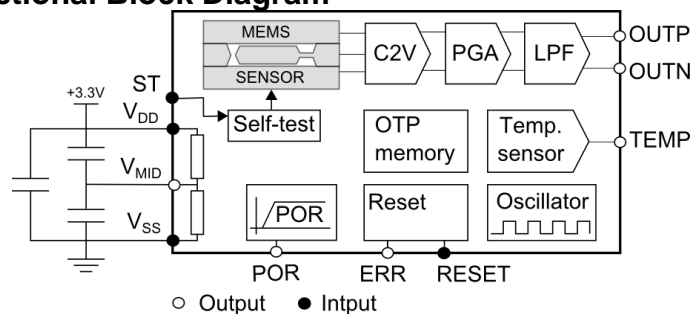

## Key features

- **High temperature range**  
-40 to 175°C
- **Low noise**  
< 7 µg @ 1 Hz for ±2 g range
- **Excellent Bias Residual model**  
< +/-0.6 mg for ± 2 g range
- **Long term Bias Stability**  
±2mg for ±2g range after extreme stability plan

Parameter, typical values	TS1002T	TS1005T	TS1010T	Unit
Full-scale acceleration	± 2	± 5	± 10	g
Angular accuracy [1]	0.1	0.25	0.5	°
Residual Bias modeling error [2]	0.6	1.5	3.0	mg
Long-term Bias stability	2	5	10	mg
Residual Scale factor modeling error [2]	300	300	300	ppm
Misalignment	10	10	10	mrad
Resolution (1Hz)	7	17	34	µg
Non Linearity (IEEE norm)	0.3	0.3	0.3	% FS
Operational temperature	-40 to +150	-40 to +150	-40 to +150	°C
Intermittent temperature	-55 to +175	-55 to +175	-55 to +175	°C
Shock Survivability	6'000	6'000	6'000	g
Endurance shock (500 times)	1500	1500	1500	g
Operating power consumption	10	10	10	mW
Size	9 x 9	9 x 9	9 x 9	mm <sup>2</sup>

[1] see definition in paragraph "Using TS1000T for Tilt Application"

[2] Using 3<sup>rd</sup> order polynomial compensation]

## Featured Applications (non-exhaustive)

### Drilling

- Down-Hole Measurement While Drilling
- Directional Drilling
- Borehole Survey
- Geological Exploration
- Logging While Drilling

**TS1002T PARAMETERS**

All values are specified at ambient temperature (20°C) and at 3.3 V supply voltage  $V_{DD}$ , unless otherwise stated. Acceleration values are defined for differential signal (OUTP-OUTN).

Parameter	Comments	Min	Typ.	Max	Unit
<b>Accelerometer</b>					
Full scale		±2			g
Non-Linearity	IEEE Norm , % of full scale		0.3	1.0	%
Non-Linearity	Under vibration, % of full scale		0.1	0.3	%
Frequency response	±3dB	100			Hz
Resonant frequency	Overdamped		1.4		kHz
Noise	in band		7		µg/√Hz
Resolution	@ 1Hz		7		µg rms
Startup time	Sensor operational, delay once POR triggered		40		µs
<b>Bias (K0)</b>					
Nominal	Calibration	-7		7	mg
Temperature coefficient	Measured between [-40°C to 150°C] @ 0.5°C/min slope		150		µg/°C
In-run bias stability	Based on Allan Variance characterization (@ 10s)		4		µg
Long-term stability [1]			2		mg
Residual Modeling error	3 <sup>rd</sup> order temperature compensation on [-40°C to 150°C]		0.6		mg
<b>Scale factor (K1)</b>					
Nominal	Calibration	1.33	1.35	1.37	V/g
Temperature coefficient	Measured between [-40°C to 150°C] @ 0.5°C/min slope	20	120	220	ppm/°C
Long-term stability [1]			1000		ppm
Residual Modeling error	3 <sup>rd</sup> order temperature compensation on [-40°C to 150°C]		300		ppm
<b>Axis misalignment</b>					
Nominal		-10		10	mrad
<b>Lifespan</b>					
Usable life expectancy	@150 °C	1000			hours
	@175 °C		50		hours
<b>Self-test</b>					
Frequency	Square wave output	22	24.4	26.8	Hz
Duty cycle			50		%
Amplitude	Peak to peak		1.3		g
Input threshold voltage	active high	80			% $V_{DD}$
<b>Temperature sensor</b>					
Output voltage @20°C		1.20	1.23	1.26	V
Sensitivity			-4.0		mV/°C
Output current load				10	µA
Output capacitive load				10	pF
<b>Reset</b>					
Input threshold voltage	active low			20	% $V_{DD}$
<b>Power requirements</b>					
Supply voltage ( $V_{DD}$ )		3.2	3.3	3.4	V
Supply current ( $I_{DD}$ )			3	4	mA

**Accelerometer outputs**

Output voltages	OutP, OutN over full scale	0.14	3.16	V
Differential output	Over full scale	±2.7		V
Resistive load		1000		kΩ
Capacitive load			100	pF

[1] The long-term stability represents the residual error defined after applying following environmental conditions: powered life test 500h @150°C, 60x temperature cycling -40°C to 150°C, random vibration @130°C (20grms / 10-2'000Hz), shock @130°C (100g / 2ms / 12'000 shocks).

Table 1: TS1002T Specifications

**TS1005T PARAMETERS**

All values are specified at ambient temperature (20°C) and at 3.3 V supply voltage  $V_{DD}$ , unless otherwise stated. Acceleration values are defined for differential signal (OUTP-OUTN).

Parameter	Comments	Min	Typ.	Max	Unit
<b>Accelerometer</b>					
Full scale		±5			g
Non-Linearity	IEEE, % of full scale		0.3	1.0	%
Non-Linearity	Under vibration, % of full scale		0.1	0.3	%
Frequency response	±3dB	100			Hz
Resonant frequency	Overdamped		2.9		kHz
Noise	in band		17		µg/√Hz
Resolution	@ 1Hz		17		µg rms
Startup time	Sensor operational, delay once POR triggered		40		µs
<b>Bias (K0)</b>					
Nominal	Calibration	-17		17	mg
Temperature coefficient	Measured between [-40°C to 150°C] @ 0.5°C/min slope		375		µg/°C
In-run bias stability	Based on Allan Variance characterization (@ 10s)		10		µg
Long-term stability [1]			5		mg
Residual Modeling error	3 <sup>rd</sup> order temperature compensation on [-40°C to 150°C]		1.5		mg
<b>Scale factor (K1)</b>					
Nominal	Calibration	532	540	548	mV/g
Temperature coefficient	Measured between [-40°C to 150°C] @ 0.5°C/min slope	20	120	220	ppm/°C
Long-term stability [1]			1000		ppm
Residual Modeling error	3 <sup>rd</sup> order temperature compensation on [-40°C to 150°C]		300		ppm
<b>Axis misalignment</b>					
Nominal		-10		10	mrad
<b>Lifespan</b>					
Usable life expectancy	@150 °C	1000			hours
	@175 °C		50		hours
<b>Self-test</b>					
Frequency	Square wave output	22	24.4	26.8	Hz
Duty cycle			50		%
Amplitude	Peak to peak		1.3		g
Input threshold voltage	active high	80			% $V_{DD}$
<b>Temperature sensor</b>					
Output voltage @20°C		1.20	1.23	1.26	V
Sensitivity			-4.0		mV/°C
Output current load				10	µA
Output capacitive load				10	pF
<b>Reset</b>					
Input threshold voltage	active low			20	% $V_{DD}$
<b>Power requirements</b>					
Supply voltage ( $V_{DD}$ )		3.2	3.3	3.4	V
Supply current ( $I_{DD}$ )			3	4	mA

**Accelerometer outputs**

Output voltages	OutP, OutN over full scale	0.14	3.16	V
Differential output	Over full scale	±2.7		V
Resistive load		1000		kΩ
Capacitive load			100	pF

[1] The long-term stability represents the residual error defined after applying following environmental conditions: powered life test 500h @150°C, 60x temperature cycling -40°C to 150°C, random vibration @130°C (20grms / 10-2'000Hz), shock @130°C (100g / 2ms / 12'000 shocks).

Table 2: TS1005T Specifications

**TS1010T PARAMETERS**

All values are specified at ambient temperature (20°C) and at 3.3 V supply voltage  $V_{DD}$ , unless otherwise stated. Acceleration values are defined for differential signal (OUTP-OUTN).

Parameter	Comments	Min	Typ.	Max	Unit
<b>Accelerometer</b>					
Full scale		±10			g
Non-Linearity	IEEE, % of full scale		0.3	1.0	%
Non-Linearity	Under vibration, % of full scale		0.1	0.3	%
Frequency response	±3dB	100			Hz
Resonant frequency	Overdamped		3.7		kHz
Noise	in band		34		µg/√Hz
Resolution	@ 1Hz		34		µg rms
Startup time	Sensor operational, delay once POR triggered		40		µs
<b>Bias (K0)</b>					
Nominal	Calibration	-34		34	mg
Temperature coefficient	Measured between [-40°C to 150°C] @ 0.5°C/min slope		750		µg/°C
In-run bias stability	Based on Allan Variance characterization (@ 10s)		20		µg
Long-term stability [1]			10		mg
Residual Modeling error	3 <sup>rd</sup> order temperature compensation on [-40°C to 150°C]		3.0		mg
<b>Scale factor (K1)</b>					
Nominal	Calibration	266	270	274	mV/g
Temperature coefficient	Measured between [-40°C to 150°C] @ 0.5°C/min slope	20	120	220	ppm/°C
Long-term stability [1]			1000		ppm
Residual Modeling error	3 <sup>rd</sup> order temperature compensation on [-40°C to 150°C]		300		ppm
<b>Axis misalignment</b>					
Nominal		-10		10	mrاد
<b>Lifespan</b>					
Usable life expectancy	@150 °C	1000			hours
	@175 °C		50		hours
<b>Self-test</b>					
Frequency	Square wave output	22	24.4	26.8	Hz
Duty cycle			50		%
Amplitude	Peak to peak		1.3		g
Input threshold voltage	active high	80			% $V_{DD}$
<b>Temperature sensor</b>					
Output voltage @20°C		1.20	1.23	1.26	V
Sensitivity			-4.0		mV/°C
Output current load				10	µA
Output capacitive load				10	pF
<b>Reset</b>					
Input threshold voltage	active low			20	% $V_{DD}$
<b>Power requirements</b>					
Supply voltage ( $V_{DD}$ )		3.2	3.3	3.4	V
Supply current ( $I_{DD}$ )			3	4	mA

**Accelerometer outputs**

Output voltages	OutP, OutN over full scale	0.14	3.16	V
Differential output	Over full scale	±2.7		V
Resistive load		1000		kΩ
Capacitive load			100	pF

[1] The long-term stability represents the residual error defined after applying following environmental conditions: powered life test 500h @150°C, 60x temperature cycling -40°C to 150°C, random vibration @130°C (20grms / 10-2'000Hz), shock @130°C (100g / 2ms / 12'000 shocks).

Table 3: TS1010T Specifications

## Absolute maximum ratings

Absolute maximum ratings are stress ratings. Stresses in excess of these ratings can cause permanent damage to the device. Exposure of the device to the absolute maximum ratings for an extended period may degrade the device and affect its reliability.

Parameter	Comments	Min	Typ	Max	Unit
Supply voltage (V <sub>DD</sub> )		-0.3		3.9	V
Voltage at any PIN		-0.3		V <sub>DD</sub> +0.3	V
Operational temperature		-40		150	°C
Survival temperature	Intermittent (50 hours @ 175°C)	-55		175	°C
Vibration	Random, 10-2'000Hz			20	grms
Multiple Shock	Functional operation after 500 shocks (0.5ms / half-sine / any axis)			1'500	g
Shock Survivability	Single shock 0.15ms half-sine, in one direction (HA, PA or IA axes)			6'000	g
ESD stress	HBM model	-1		1	kV

Table 4: Absolute maximum ratings



**Typical performances characteristics**

TS1002T: Typical performances on multiple sensor at 3.3 VDC supply voltage (V<sub>DD</sub>) and ambient temperature for all graphs, unless otherwise stated

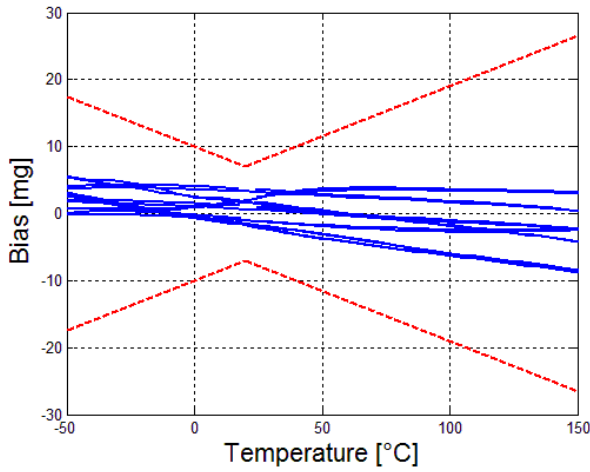

Figure 1: Raw Bias over temperature

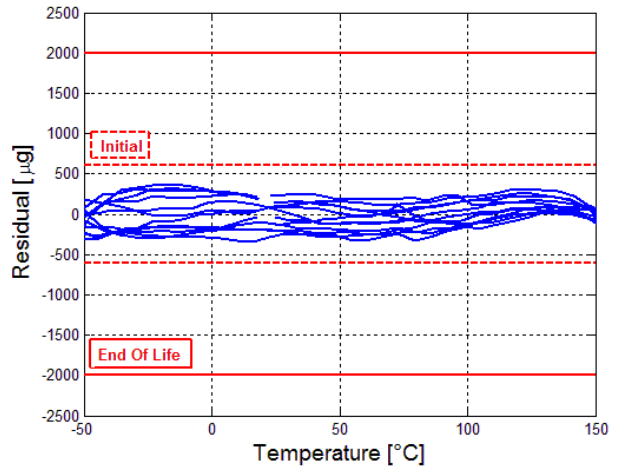

Figure 2 : Residual Bias over temperature

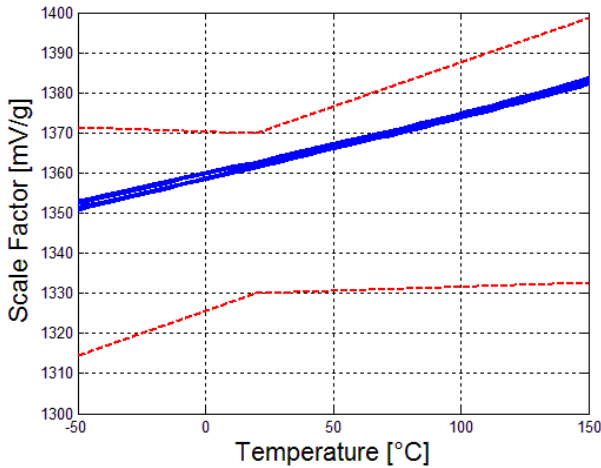

Figure 3: Raw Scale Factor over temperature

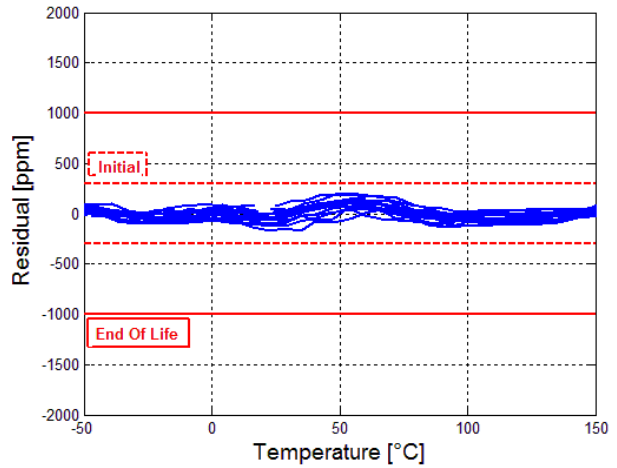

Figure 4: Residual Scale Factor over temperature

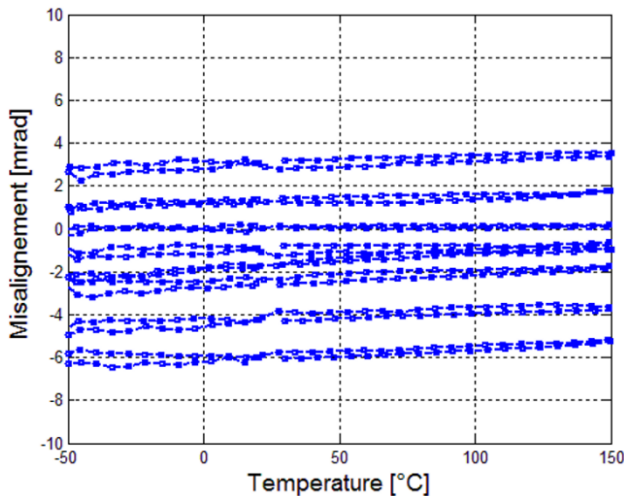

Figure 5: Raw Misalignment over temperature

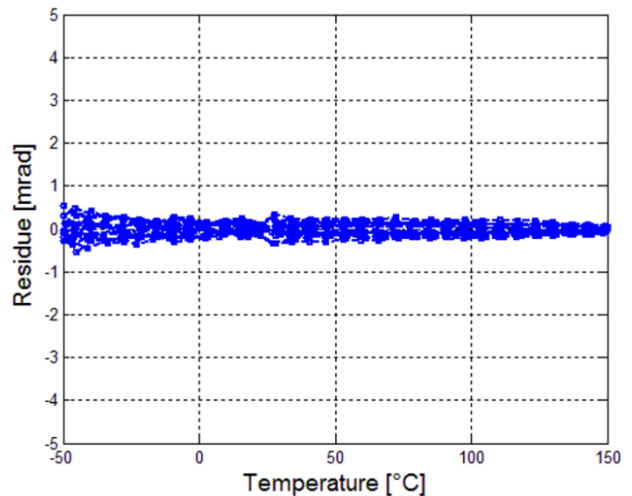

Figure 6: Residual Misalignment over temperature

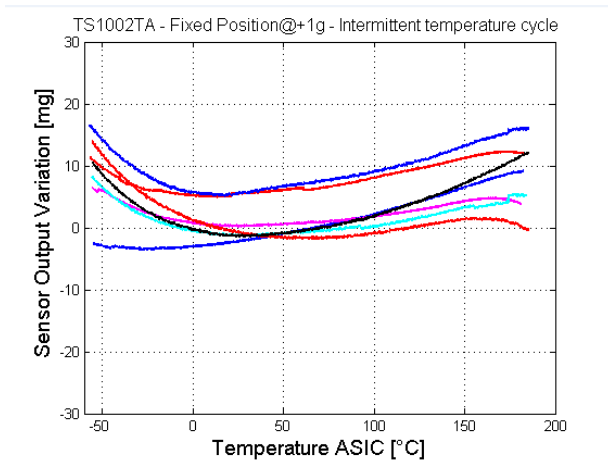

Figure 7 : Sensor output up to intermittent 175°C

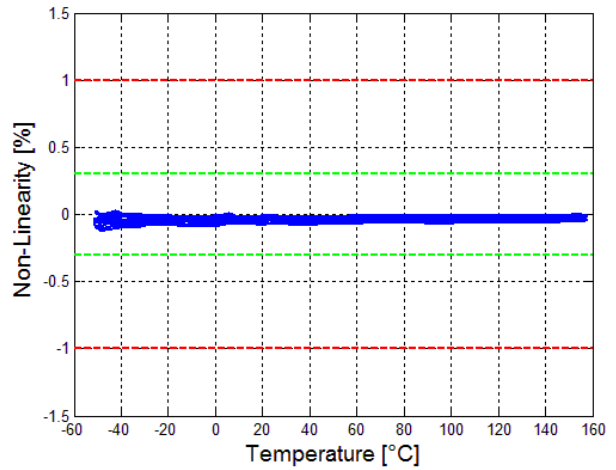

Figure 8 : Non-linearity at +/-1g over temperature

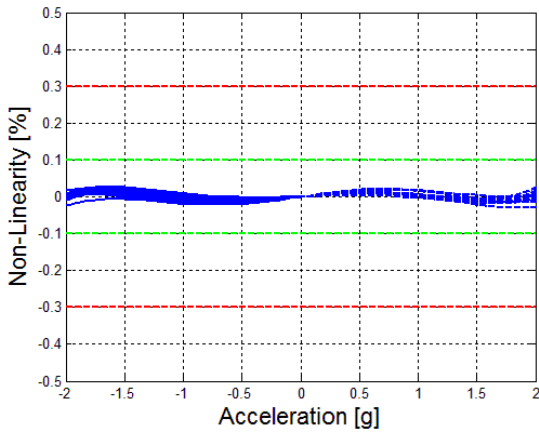

Figure 9 : Non-linearity under vibration

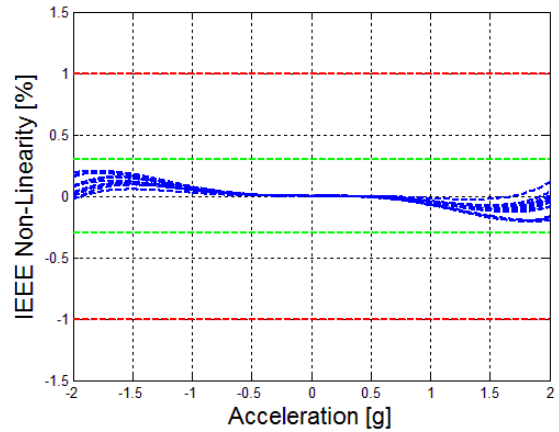

Figure 10 : Non-linearity IEEE

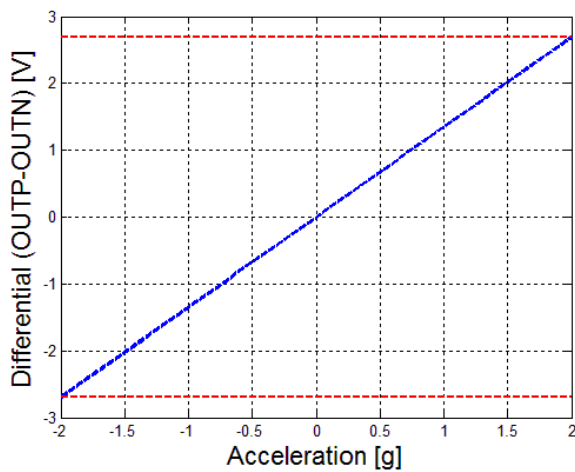

Figure 11 : Differential acceleration output (OUTP-OUTN) at full scale

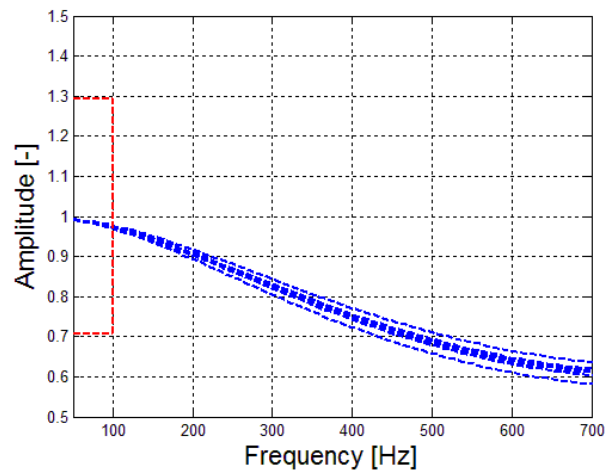

Figure 12 : Frequency response

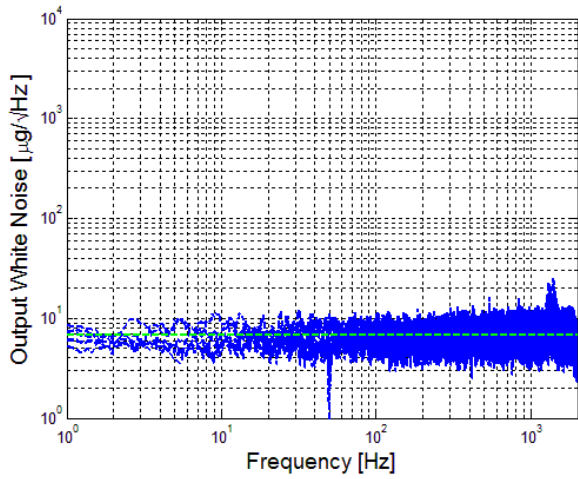

Figure 13: Typical white noise

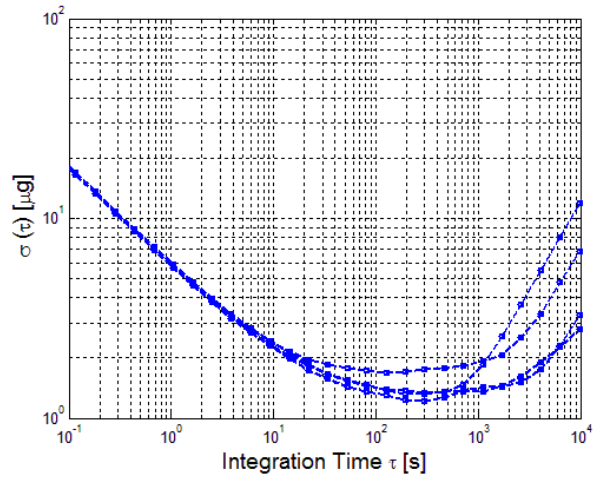

Figure 14: Allan Variance

**Typical performances characteristics**

**TS1005T:** Typical performances on multiple sensor at 3.3 VDC supply voltage (V<sub>DD</sub>) and ambient temperature for all graphs, unless otherwise stated

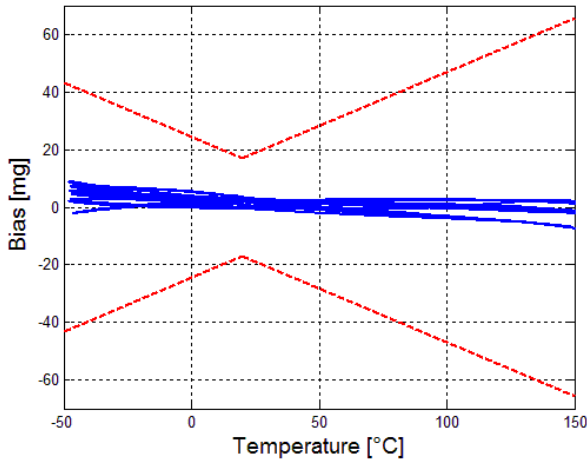

Figure 15: Raw Bias over temperature

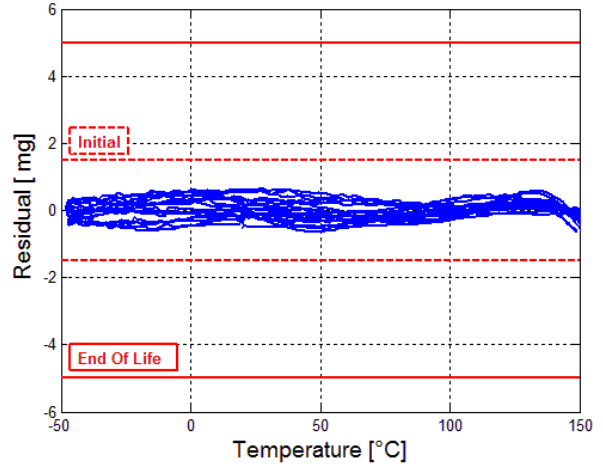

Figure 16 : Residual Bias over temperature

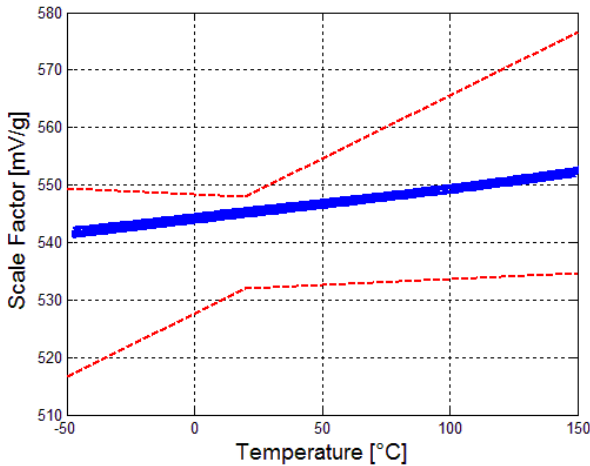

Figure 17: Raw Scale Factor over temperature

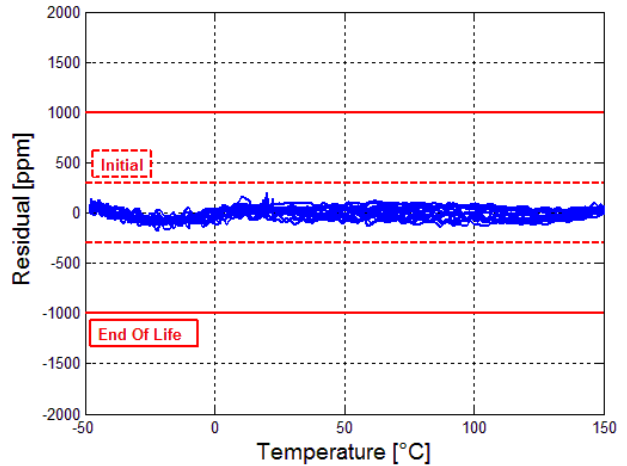

Figure 18: Residual Scale Factor over temperature

TBA

Figure 19: Raw Misalignment over temperature

TBA

Figure 20: Residual Misalignment over temperature

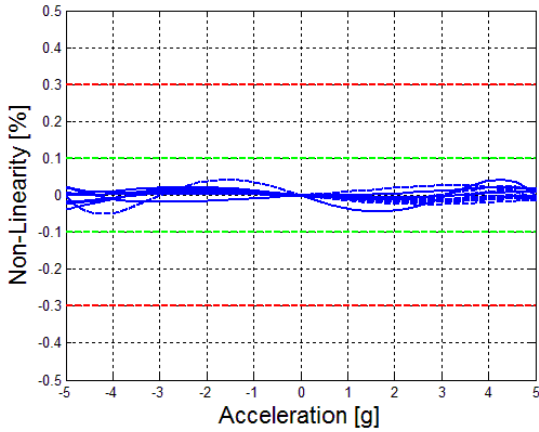

Figure 21 : Non-linearity under vibration

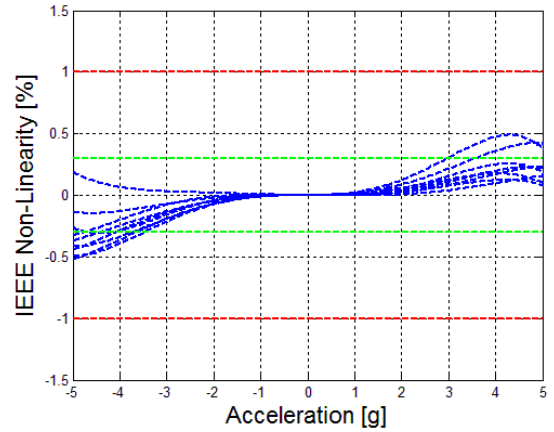

Figure 22 : Non-linearity IEEE

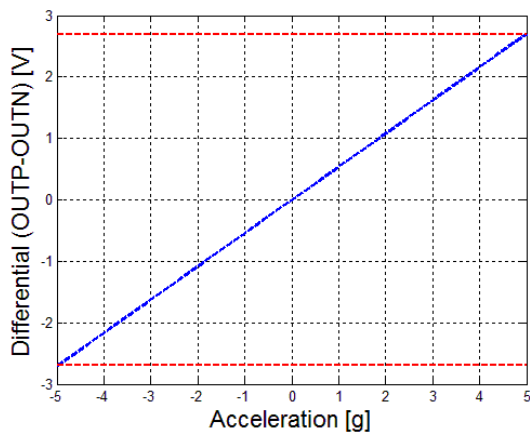

Figure 23 : Differential acceleration output (OUTP-OUTN) at full scale

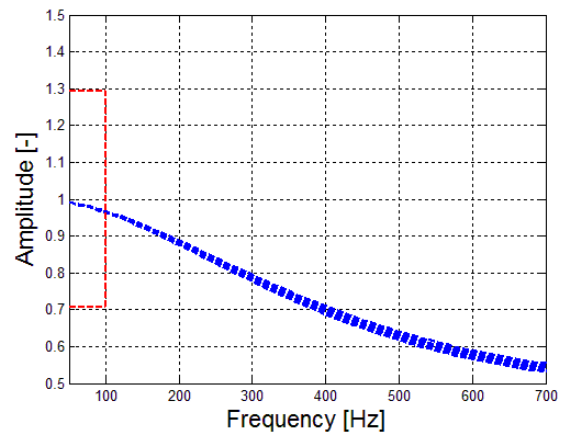

Figure 24 : Frequency response

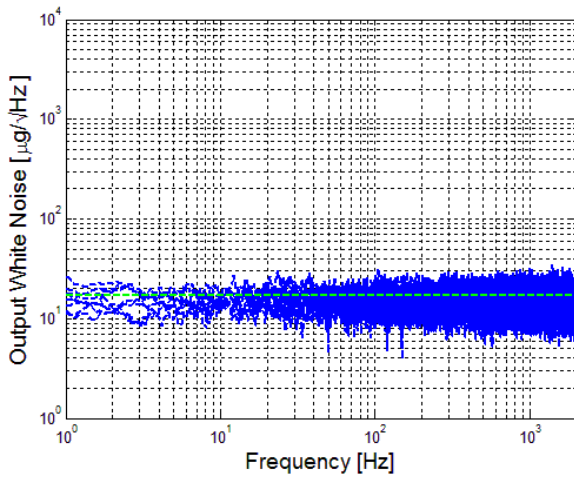

Figure 25: Typical white noise

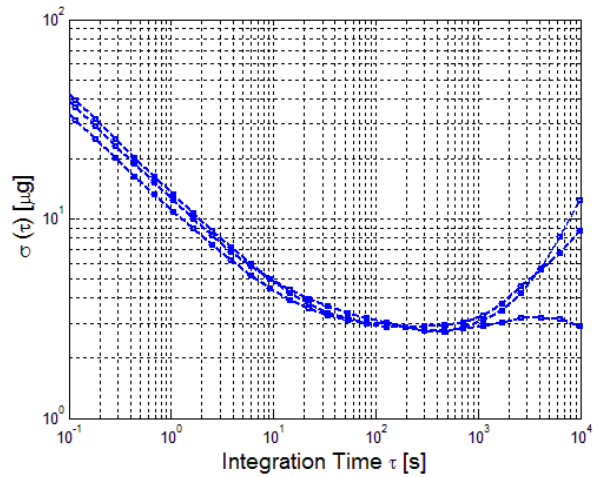

Figure 26: Allan Variance

**Typical performances characteristics**

**TS1010T:** Typical performances on multiple sensor at 3.3 VDC supply voltage (V<sub>DD</sub>) and ambient temperature for all graphs, unless otherwise stated

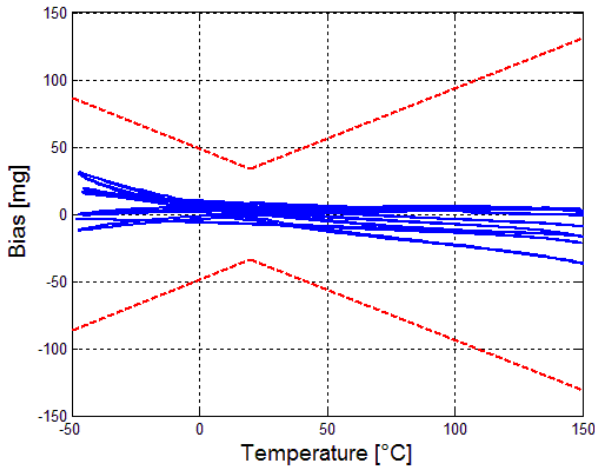

Figure 27: Raw Bias over temperature

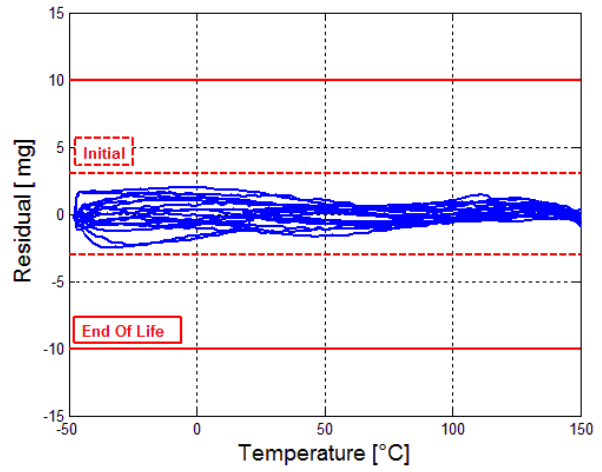

Figure 28 : Residual Bias over temperature

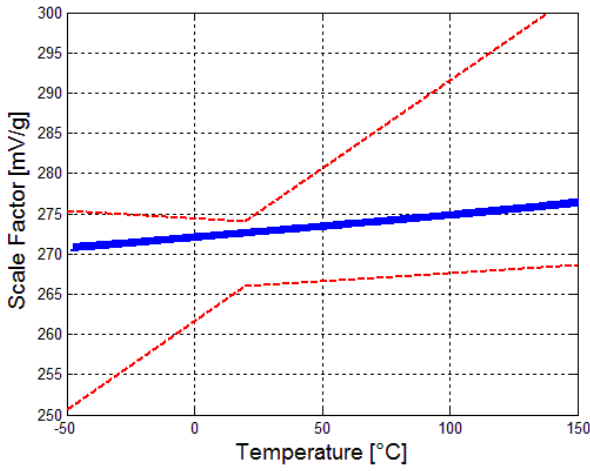

Figure 29: Raw Scale Factor over temperature

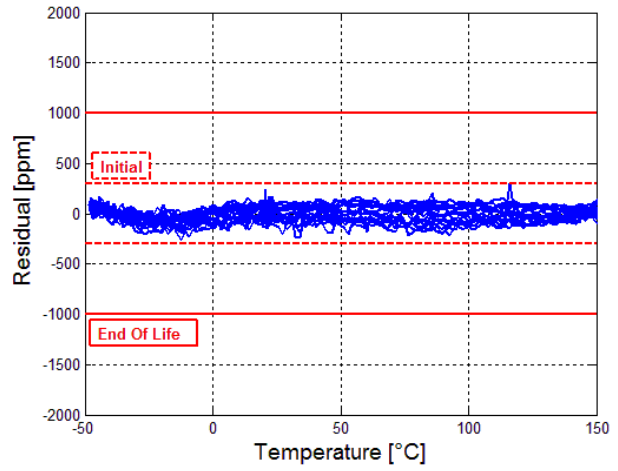

Figure 30: Residual Scale Factor over temperature

TBA

Figure 31: Raw Misalignment over temperature

TBA

Figure 32: Residual Misalignment over temperature

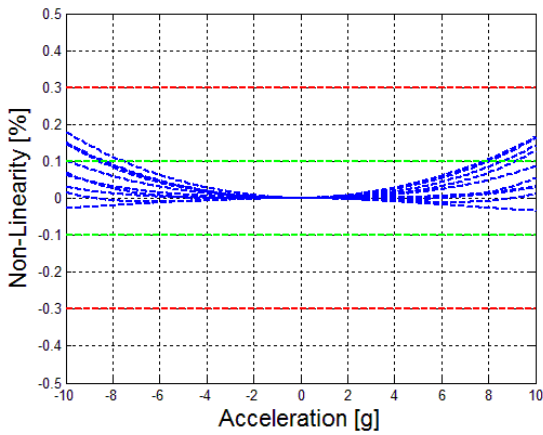

Figure 33 : Non-linearity under vibration

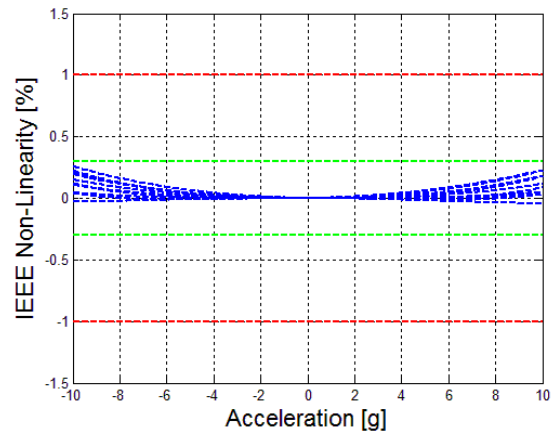

Figure 34 : Non-linearity IEEE

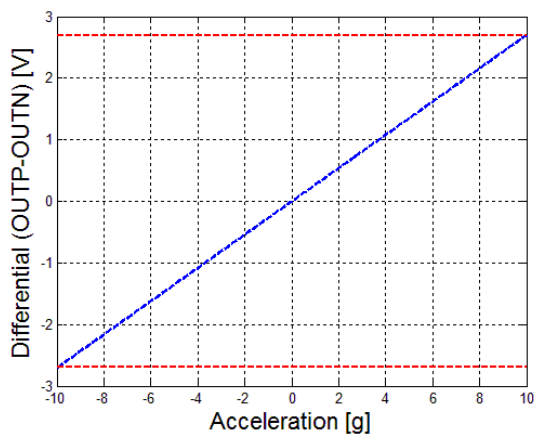

Figure 35 : Differential acceleration output (OUTP-OUTN) at full scale

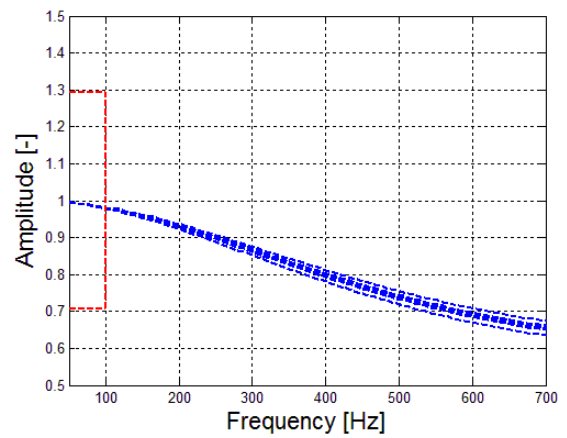

Figure 36 : Frequency response

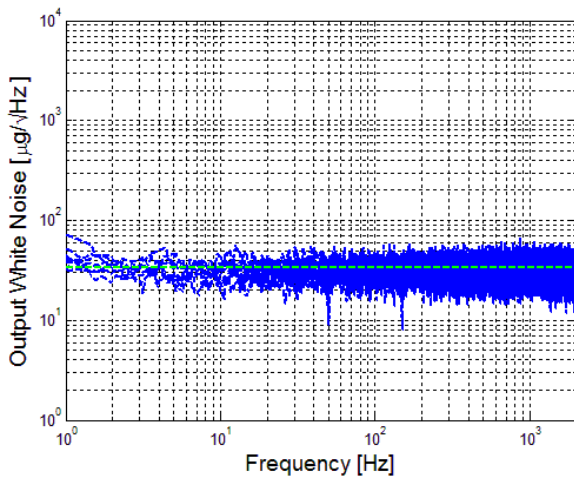

Figure 37: Typical white noise

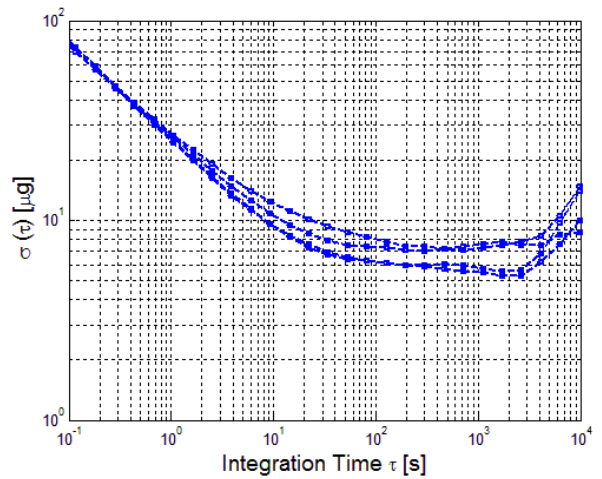

Figure 38: Allan Variance

### Pinout description

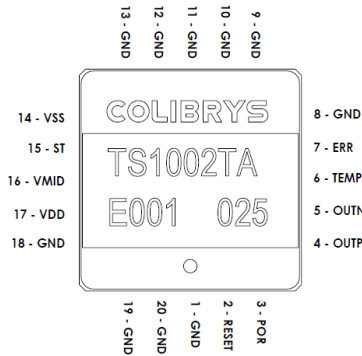

Figure 39: Pinout top view

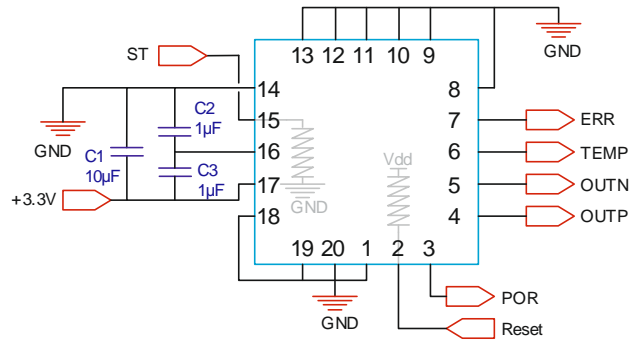

Figure 40: Proximity circuit & internal pull-up/down

The device pin layout is given in Figure 39 and a description of each pin given in the Table 5. The capacitors C1 (10 µF), C2 (1 µF) and C3 (1 µF) are shown in Figure 40 and must be placed as close as possible to the TS1000T package and are used as decoupling capacitors and for a proper sensor startup.

Pin Nb.	Pin name	Type	Description
2	RESET	DI, PU	System reset signal, active low
3	POR	DO	Power On Reset
4	OUTP	AO	Differential output positive signal
5	OUTN	AO	Differential output negative signal
6	TEMP	AO	Temperature analogue output
7	ERR	DO	Error signal (flag)
14	V <sub>SS</sub> (0 V)	PWR	Connect to ground plane
15	ST	DI, PD	Self-test activation, active high
16	V <sub>MID</sub>	AO	Internal ASIC reference voltage. For decoupling capacitors only
17	V <sub>DD</sub> (3.3 V)	PWR	Analogue power supply
1,8,9,10,11,12,13,18,19,20	GND	GND	Must be connected to ground plane (GND)

*PWR, power / AO, analog output / AI, analog input / DO, digital output / DI, digital input / PD, internal pull down / PU, internal pull up*

Table 5: TS1000T pinout description



## Electrical Functions description

### Introduction

TS1000T as electrical digital function embedded such as Power-On-Reset, External reset, Built in Self-test and Overload error detection. All those functions are described bellows.

### POR (Power-On-Reset) function

The POR block continuously monitors the power supply during startup as well as normal operation. It ensures a proper startup of the sensor and acts as a brownout protection in case of a drop in supply voltage.

During sensor power on, the POR signal stays low until the supply voltage reaches the POR threshold voltage ( $V_{TH}$ ) and begins the startup sequence (see Figure 41). In case of a supply voltage drop, the POR signal will stay low until the supply voltage exceeds  $V_{TH}$  and is followed by a new startup sequence. The ERR signal is high (equal to  $V_{DD}$ ) until the startup sequence is complete.

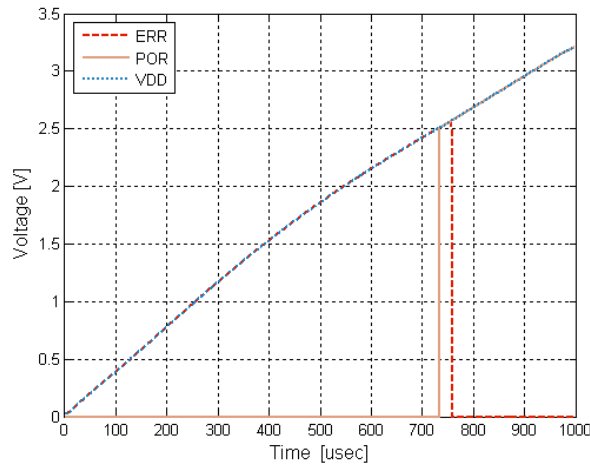

Figure 41: Typical sensor power sequence using the recommended circuit

### External Reset

An external reset can be activated by the user through the RESET input pin. During a reset phase, the accelerometer outputs (OUTP & OUTN) are forced to  $V_{DD} / 2$  and the error signal (ERR) is activated (high), see Figure 42.

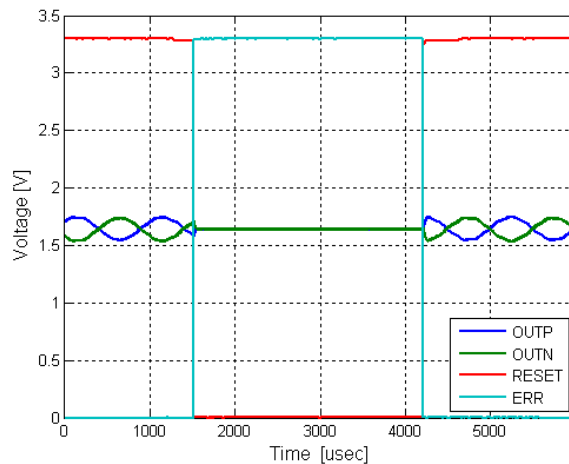

Figure 42: Typical sensor reset sequence with external reset

**Built-in Self-Test function**

The built-in Self-Test mode generates a square wave signal on the device outputs (OUTP & OUTN) and can be used for device failure detection (see Figure 43).

When activated, it induces an alternating electrostatic force on the mechanical sensing element and emulates an input acceleration at a defined frequency. This electrostatic force is in addition to any inertial acceleration acting on the sensor during self-test; therefore it is recommended to use the self-test function under quiescent conditions.

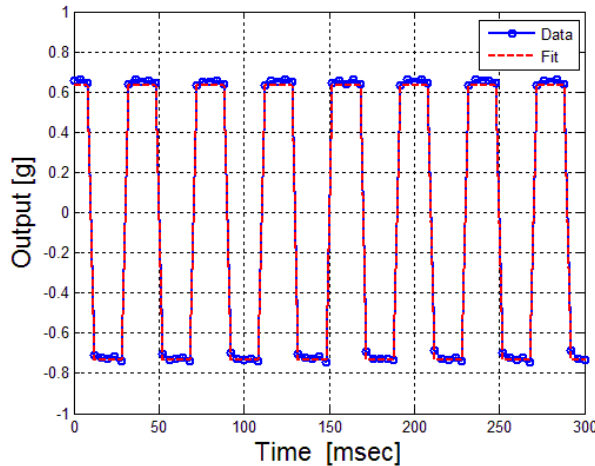

Figure 43: Built-in Self-Test signal on the differential acceleration output (frequency: 24 Hz / amplitude 1.3 g)

**Overload and error function**

The device continuously monitors the validity of the accelerometer output signals. If an error occurs, the ERR pin goes high and informs the user that the output signals are not valid. An error can be raised in the following cases:

- Out-of-tolerance power supply voltage (POR low), such as during power on
- During external reset phase (user activation of the reset)
- Under high acceleration overload (e.g. high shock)

Upon a high-amplitude shock, the internal overload circuit resets the electronics and initiates a new startup of the readout electronics. This sequence is repeated until the acceleration input signal returns to normal operation range. This behavior is illustrated on the figure below with a large shock of amplitude 1'500 g: the overload protection is active during the shock and the sensor is fully operational once the acceleration is within the operating range

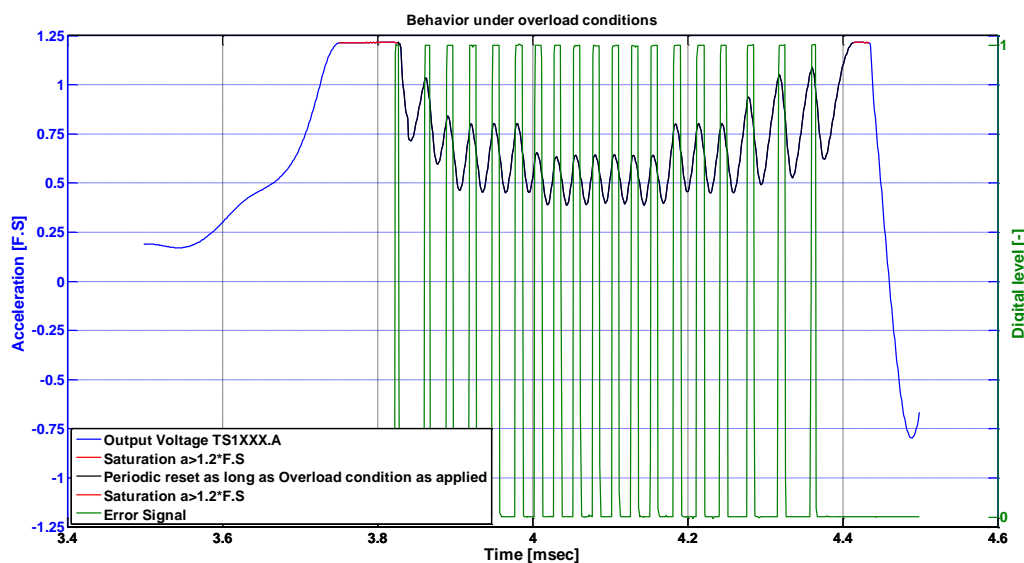

Figure 44: Overload Behavior

## Dimensions and package specifications

The outline of the LCC20 ceramic package and the Center of Gravity (CG) is illustrated in the Figure 45.

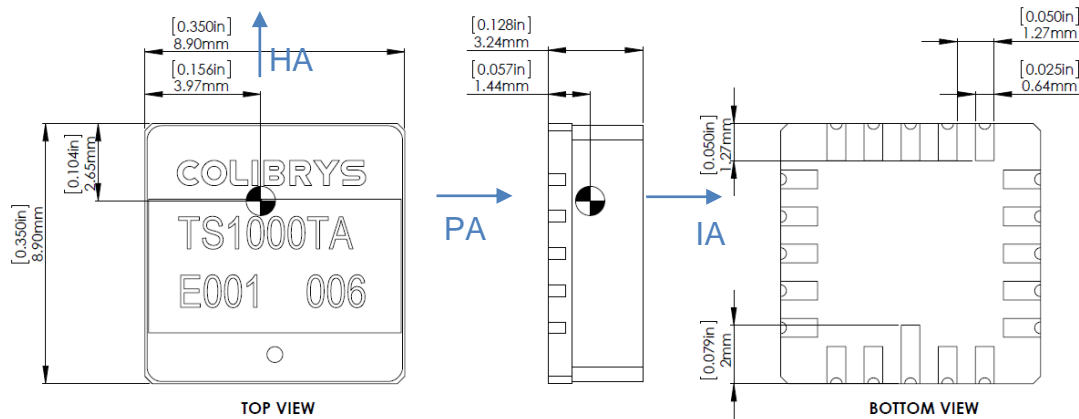

Figure 45: Package mechanical dimension. Units are mm [inch]

Parameter	Comments	Min	Typ	Max	Unit
Lead finishing	Au plating	0.5		1.5	µm
	Ni plating	1.27	4	8.89	µm
	W (tungsten)	10		15	µm
Hermeticity	According to MIL-STD-833-G			5-10-8	atm·cm <sup>3</sup> /s
Weight				1.5	grams
Size	X		8.9	9.2	mm
	Y		8.9	9.2	mm
	Z		3.23	3.5	mm
Packaging	RoHS compliant part. Nonmagnetic, LCC20 pin housing.				
Proximity effect	The sensor is sensitive to external parasitic capacitance. Moving metallic objects with large mass or parasitic effect in close proximity of the accelerometer (mm range) must be avoided to insure best product performances. A ground plane below the accelerometer is recommended as a shielding.				
Reference plane for axis alignment	LCC must be tightly fixed to the ceramic board, using the bottom of the housing as the reference plane for axis alignment. Using the lid as reference plane or for assembly may affect specifications and product reliability (i.e. axis alignment and/or lid soldering integrity)				

Table 6: Package specifications

## Recommended circuit

In order to obtain the best device performance, particular attention must be paid to the proximity analog electronics, which includes the reference voltage, the sensor decoupling capacitors and the output buffers (see block diagram in Figure 46).

Optimal acceleration measurements are obtained using the differential output (OUTP – OUTN). If a single-ended acceleration signal is required, it must be generated from the differential acceleration output in order to remove the common mode noise.

### Block Diagram

The main blocks that require particular attention are the power supply management, the accelerometer sensor electronic and the output buffer. The following schematic shows an example of TS1000T implementation.

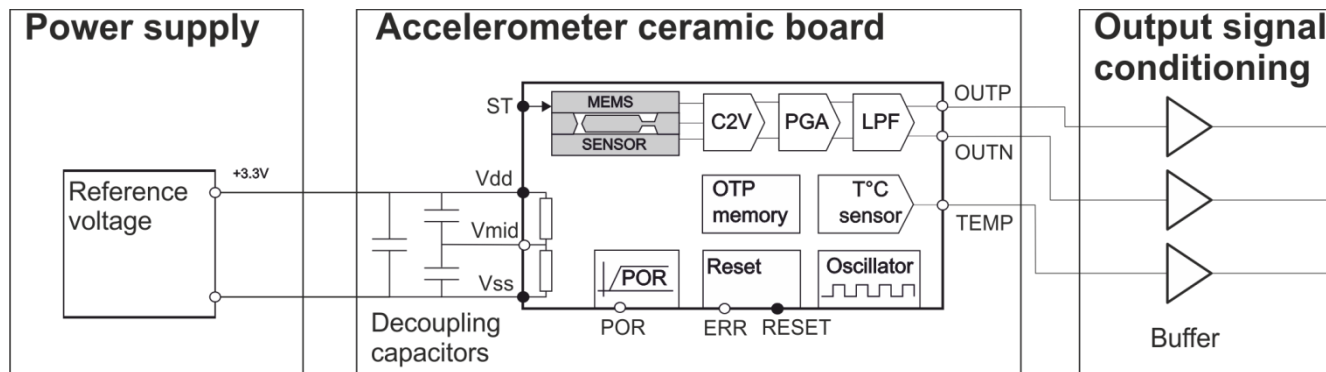

Figure 46: Block diagram

### Power Supply

The accelerometer output is ratiometric to the power supply voltage and its performance will directly impact the accelerometer bias, scale factor, noise and thermal performance. Therefore, a low-noise, high-stability and low-thermal drift power supply is recommended. Key performances are:

- Output noise <  $1\mu\text{V}/\sqrt{\text{Hz}}$
- Output temperature coefficient <  $10\text{ppm}/^\circ\text{C}$

The power supply can be used as an output signal ( $V_{DD}$ ) in order to compensate any variation on the power supply voltage that will impact the accelerometer signal (ratiometric output).

The electronic circuit within the accelerometer is based on a switched-capacitor architecture clocked @ 200 kHz. High-frequency noise or spikes on the power supply will affect the outputs and induce a signal within the device bandwidth.

### Accelerometer ceramic board

The ceramic board is composed of the TS1000T accelerometer and the proximity circuit composed of the 3 decoupling capacitors: C1, C2 and C3. These capacitors are mandatory for the proper operation and full performance of the accelerometer. We recommend placing them as close as possible to the TS1000T package on the ceramic board.

### Output signal conditioning

The output buffer must be correctly selected in order to match the TS1000T output impedance and signal bandwidth. If an analog to digital converter is involved, we recommend using a component with an external voltage reference – which shall be derived from the power supply of the accelerometer  $V_{DD}$ . Such an implementation takes into account by design the ratiometric behavior of the accelerometer output.

### Temperature compensation

The TS1000T delivers an output signal without any internal temperature compensation. The intrinsic temperature coefficient is quite small but can be further improved through a calibration, using the temperature provided by the internal temperature sensor. Third-order compensation is generally required for a coherent modeling of a TS1000T.

## Circuit type- integration recommendation

The stresses induced by the coefficient of thermal expansion (CTE) mismatch between a PCB and the alumina ceramic TS1000T package will impact global sensor performances, especially during large temperature excursions. In order to optimize stress homogeneity, minimize bias residual error and improve long-term stability, the sensor should be assembled on a ceramic board (eg: Al<sub>2</sub>O<sub>3</sub> material) which matches the TS1000T package CTE of 7 ppm/°C. We also recommend all metal pads of the accelerometer be soldered.

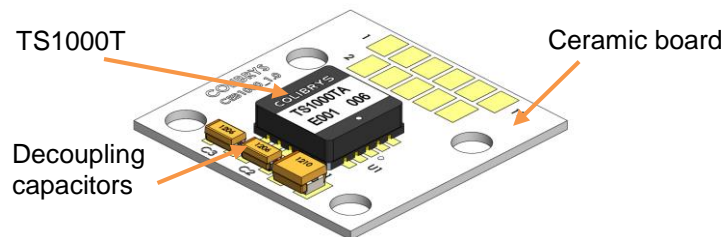

Figure 47: Illustration of a ceramic evaluation board with TS1000T and decoupling capacitors

## Customer test and Evaluation

For evaluation purpose, Colibrys proposes a Ceramic Evaluation Board (CEB1000\_1) as a sale option.

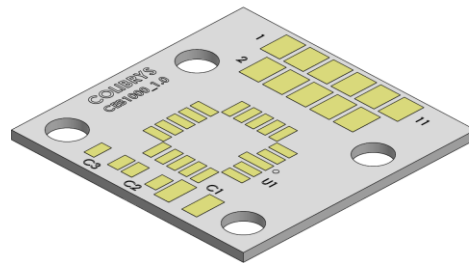

Figure 48 : Ceramic Evaluation Board (CEB1000\_1) for LCC20. Dimension: 25mm x 25mm

### SMD recommendation

A recommended land pattern for LCC20 is shown in the Figure 49. It should be tested and qualified in the manufacturing process. The land pattern and pad sizes have a pitch of 1.27mm and the pin 1 is longer to insure the right orientation of the product during mounting. After assembly, the orientation can be controlled from the top with an extra point printed on the lid which correspond to pin 1.

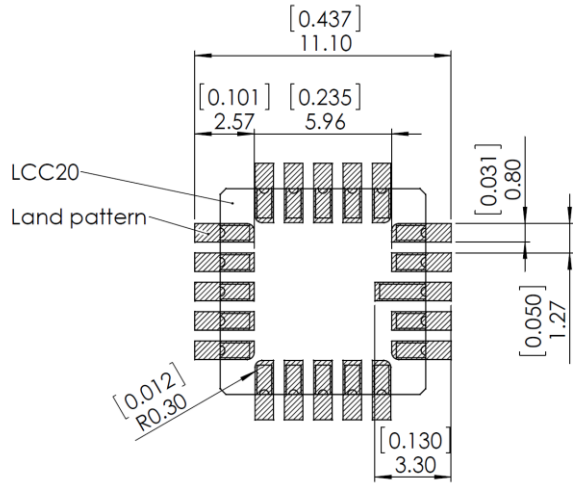

Figure 49 LCC20 land pattern recommendation (unit are mm/[inch])

The TS1000T is suitable for Sn/Pb and Pb-Free soldering and ROHs compliant. Typical temperature profiles recommended by the solder manufacturer can be used with a maximum ramp-up of 3°C/second and a maximum ramp-down of 6°C/second: The exact profile depends on the used solder paste.

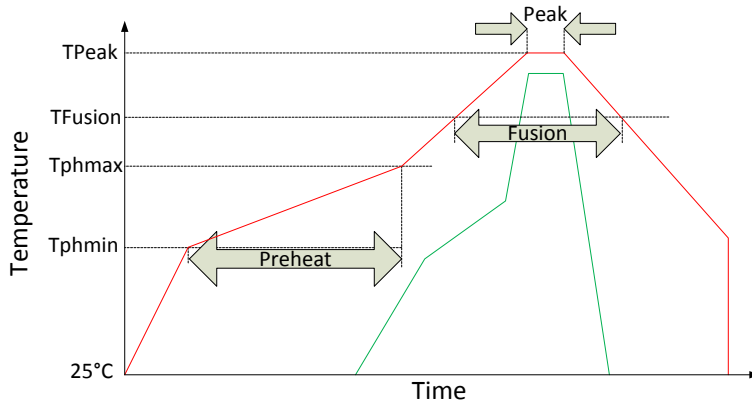

Figure 50: Soldering Temperature Profile

Phase	Sn/Pb		Pb-Free	
	Duration [sec]	Temperature [°C]	Duration [sec]	Temperature [°C]
Peak	10-30	235-240	20-40	245-250
Fusion	60-150	183	60-150	217
Preheat	60-120	Min : 100 Max : 150	60-180	Min : 150 Max : 200

Table 7: Soldering temperatures & times

The cleaning process of electronic boards sometimes involves ultrasounds. This is strongly prohibited on our sensors. Ultrasonic cleaning will have a negative impact on silicon elements which generally causes damages.



**Note: Ultrasonic cleaning is forbidden in order to avoid damage of the MEMS accelerometer**

## Handling and packaging precautions

### Handling

The TS1000T is packaged in a hermetic ceramic housing to protect the sensor from the ambient environment. However, poor handling of the product can induce damage to the hermetic seal (Glass frit) or to the ceramic package made of brittle material (alumina). It can also induce internal damage to the MEMS accelerometer that may not be visible and cause electrical failure or reliability issues. Handle the component with caution: shocks, such as dropping the accelerometer on hard surface, may damage the product.



**It is strongly recommended to use vacuum pens to manipulate the accelerometers**

The component is susceptible to damage due to electrostatic discharge (ESD). Therefore, suitable precautions shall be employed during all phases of manufacturing, testing, packaging, shipment and handling. Accelerometer will be supplied in antistatic bag with ESD warning label and they should be left in this packaging until use. The following guidelines are recommended:

- Always manipulate the devices in an ESD-controlled environment
- Always store the devices in a shielded environment that protects against ESD damage (at minimum an ESD-safe tray and an antistatic bag)
- Always wear a wrist strap when handling the devices and use ESD-safe gloves



**This product can be damaged by electrostatic discharge (ESD). Handle with appropriate precautions.**

### Packaging

Our device are placed for shipment and SMD process in trays. They are packed in sealed ESD-inner bag. We strongly advice to maintain our device in is original OEM sealed ESD inner-bag to guarantee storage condition before to soldering them.

## Product identification markings

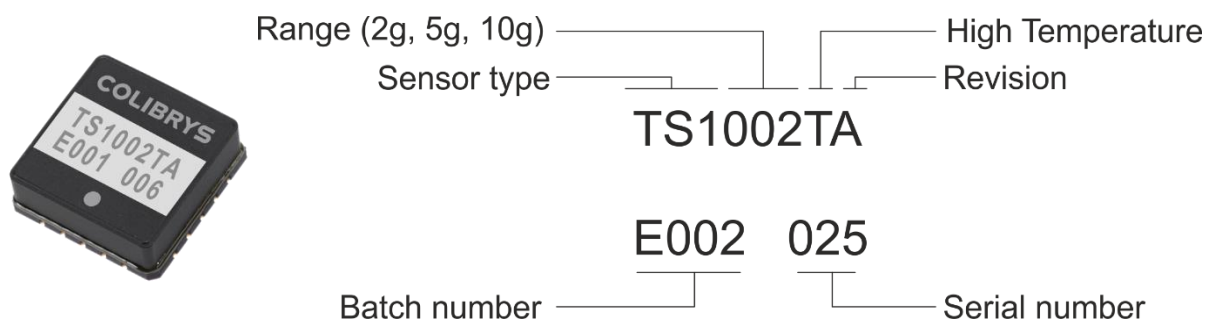

## Ordering Information

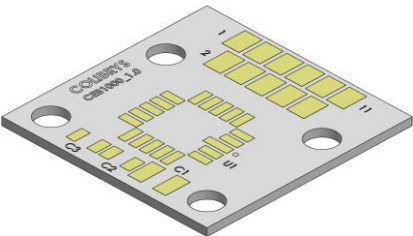
Description	Product	Measurement range	Colibrys reference number
Single analogue axis MEMS accelerometer, High temperature 	TS1002TA	±2g	37610502
	TS1005TA	±5g	37610505
	TS1010TA	±10g	37610510
Ceramic Evaluation board for LCC20 package 	CEB1000_1	NA	57610001



## Using TS1000T for Tilt Application

Using the acceleration signal of TS1000T accelerometer to extract the sensor heading requires 2 steps:

- Step1 : Sensor modelling
- Step2 : Signal compensation

The following model describes tilt estimation using 2 axes ( $A_h=0$ ). The generic model can be simplified within the 1<sup>st</sup> step, the non-idealities of the sensor will be modelled during a temperature cycle.

$K_0, K_1, K_2, K_3, K_P$  and  $K_{SP}$  will be modelled with respect to the output of the TEMP pin assuming the 2axes model below:

$$\frac{OUT_P - OUT_N}{V_{DD}} * 3.3 = K_1(T) * [K_0(T) + A_s + K_2(T) * A_s^2 + K_3(T) * A_s^3 + K_p(T) * A_p + K_{sp}(T) * A_p * A_s + E]$$

The compensation model uses a 3<sup>rd</sup> order polynomial for  $K_0(T), K_1(T), K_2(T), K_3(T)$  a 1<sup>st</sup> order for  $K_P(T)$  and a constant for  $K_{sp}$ . The 2<sup>nd</sup> step consists in subtracting all the modelled errors of the 1<sup>st</sup> step and to convert the obtained signal into an angular vector. The compensation model is given in the figure below.

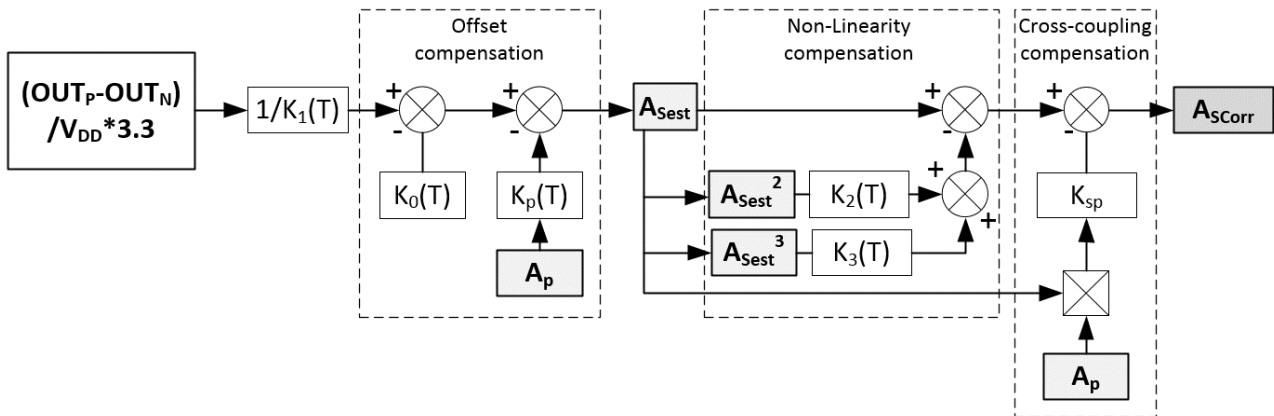

Figure 51 : Recommended compensation scheme

T or TEMP correspond to the voltage measured on the TEMP pin of the sensor.

$A_{Sest}$  corresponds to the acceleration estimated using only  $K_0, K_1$  and  $K_P$  compensation.

$A_{Scorr}$  corresponds to the detected acceleration compensated from all modelled errors.

The transformation from acceleration (g) to angle (°) can be done using the arctangent function.

$$\theta = \arctan\left(\frac{A_{Scorr}}{A_p}\right)$$

The angular performances obtained using the recommended compensation scheme shows an angular accuracy well below 0.1°.

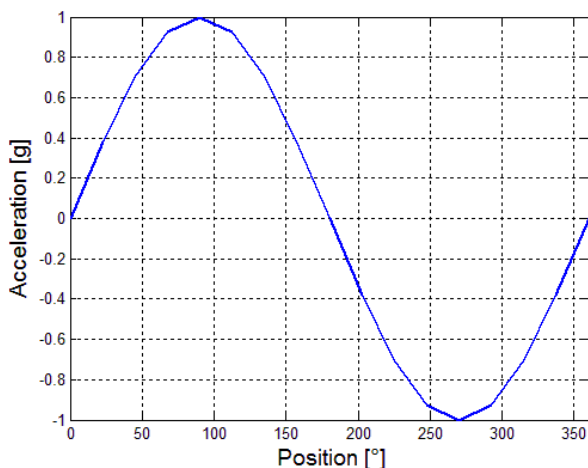

Figure 52: Position to acceleration conversion

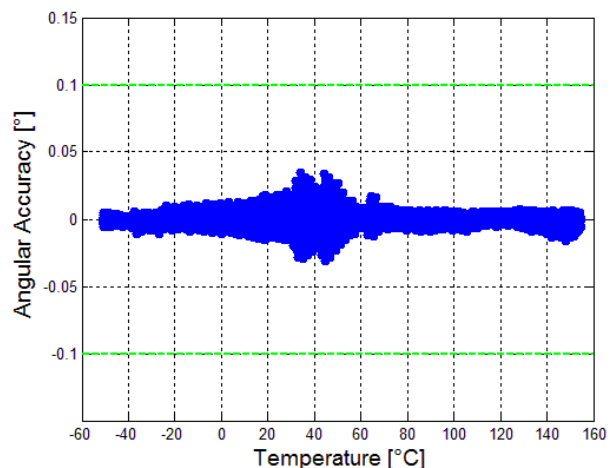

Figure 53: Angular accuracy over temperature of a TS1002TA sensor

## Glossary of parameters of the Data Sheet

### Accelerometer model

$$\frac{OUT_P - OUT_N}{V_{DD}} * 3.3 = K_1(K_0 + A_s + K_2 \cdot A_s^2 + K_3 \cdot A_s^3 + K_p \cdot A_p + K_h * A_h + K_{sp} * A_s A_p + K_{sh} * A_s A_h + E)$$

$A_s, A_p, A_h$  are the accelerations for each axes of the sensor with:

Input Axis (SA): Sensitive axis

Pendulous Axis (PA): Aligned with the proof mass beam and perpendicular to the input axis

Hinge Axis (HA): Perpendicular to the input and pendulous axes. Direction of the dot.

$K_1$  is accelerometer scale factor [V/g]

$K_0$  is bias [g]

$K_2$  is second order non-linearity [g/g<sup>2</sup>]

$K_3$  is third order non-linearity [g/g<sup>3</sup>]

$K_p$  is pendulous cross-axis [rad]

$K_h$  is output cross-axis [rad]

$K_{sp}, K_{io}$  are cross-coupling coefficients [rad/g]

$E$  is the residual noise [g]

### g [m/s<sup>2</sup>]

Unit of acceleration, equal to standard value of the earth gravity (Accelerometer specifications and data supplied by Colibrys use 9.80665 m/s<sup>2</sup>).

### Bias [mg]

The accelerometer output at zero g.

### Bias temperature coefficient [mg/°C]

Variation of the bias under variable external temperature conditions (slope of the best fit straight line through the curve of bias vs. temperature).

### Scale factor [mV/g]

The ratio of the change in output (in volts) to a unit change of the input (in units of acceleration); thus given in mV/g.

### Scale factor temperature coefficient [ppm/°C]

Maximum deviation of the scale factor under variable external temperature conditions.

### Temperature sensitivity

Sensitivity of a given performance characteristic (typically scale factor, bias, or axis misalignment) to operating temperature, specified generally at 20°C. Expressed as the change of the characteristic per degree of temperature change; a signed quantity, typically in ppm/°C for scale factor and mg/°C for bias. This figure is useful for predicting maximum scale factor error with temperature, as a variable when modelling is not accomplished.

### Non-linearity, under vibration [% FS]

The maximum deviation of accelerometer output from the best linear fit over the full scale input acceleration (sinusoidal input). The deviation is expressed as a percentage of the full-scale output (+A<sub>FS</sub>).

### Non-linearity, IEEE [% FS]

Absolute maximum error versus full-scale acceleration

$$NL_{max} \equiv \left| \frac{V - K_1(K_0 + A)}{K_1 A_{FS}} \right| = \left| \frac{K_2 A^2 + K_3 A^3 + \dots}{A_{FS}} \right|$$

### Frequency response [Hz]

Frequency range from DC to the specified value where the variation in the frequency response amplitude is less than ±3 dB

### Noise [µg/√Hz]

Undesired perturbations in the accelerometer output signal, which are generally uncorrelated with desired or anticipated input accelerations.

## Quality

Colibrys is ISO 9001:2008, ISO 14001:2004 and OHSAS 18001:2007 certified



Colibrys is in compliant with the European Community Regulation on chemicals and their safe use (EC 1907/2006) REACH.



TS1000T products comply with the EU-RoHS directive 2011/65/EC (Restrictions on hazardous substances) regulations



Recycling : please use appropriate recycling process for electrical and electronic components (DEEE)



TS1000T products are compliant with the Swiss LSPro : 930.11 dedicated to the security of products

Note:

- *TS1000T accelerometers are available for sales to professional only*
- *Les accéléromètres TS1000T ne sont disponibles à la vente que pour des clients professionnels*
- *Die Produkte der Serie TS1000T sind nur im Vertrieb für kommerzielle Kunden verfügbar*
- *Gli accelerometri TS1000T sono disponibili alla vendita soltanto per clienti professionisti*

Colibrys complies with due diligence requirements of Section 1502, Conflict Minerals, of the US Dodd-Frank Wall Street Reform and Consumer Protection Act and follows latest standard EICC/GeSI templates for Conflict Material declaration

